

EATON

Vickers

Proportional Two-Stage Directional Valves
Servo Performance with Double Spool Feedback
Pressures to 350 bar (5000 psi)

KBHDG5V-5/7/8, 10 Series

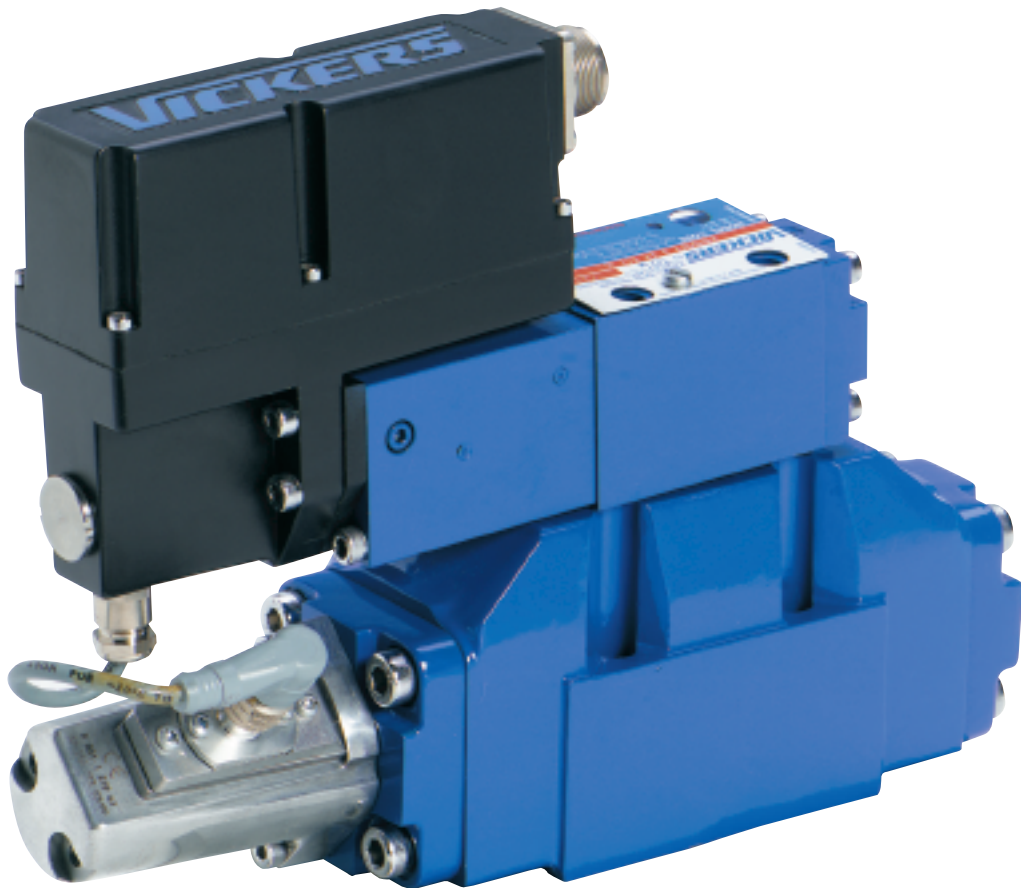

VICKERS[®]

Contents

Introduction	
General Description	3
Features and Benefits	3
Typical Section	3
Model Code	4
Spool Data	5
Functional Symbol	5
Operating Data	6
Pressures and Minimum Flow Rates	7
Performance Curves	
Power Capacity Envelope	8
Pressure Gain	8
Frequency Response	8
Flow Gain	9
Dimension KBHDG5V-5/7/8	11
Mounting Surface Interface KBHDG5V-5/7/8	13
Electrical Information	
Block Diagram	15
Typical Connection Arrangements	16
Application Data	
Fluid Cleanliness	17
Hydraulic Fluids	17
Installation	17
Mounting Bolt Kits	17
Seal Kits	17
Plugs	17
Extension Cable	17
Service Information	17

Introduction

General Description

Vickers proportional valves shown in this catalog are suitable for working pressures up to 350 bar (5000 psi) and flow rates to 375 l/min (99 USgpm).

They are designed to provide a controlled oil flow in proportion to a command signal, with spool position feedback to provide accurate control. Zero lapped spools are available for closed loop control applications and hydrostats are available for load compensation.

KBHDG5V-5/7/8

A range of proportional directional valves with control amplifiers built directly on, and prewired to the valves. Factory-set adjustments of gain, spool deadband compensation, and offset ensure high valve-to-valve reproducibility.

The only electrical inputs required are power supply (24V) and a voltage command signal of $\pm 10V$. The amplifier is housed in a robust metal enclosure, sealed against ingress of water and other fluids. Electrical connections are via a standard 7-pin plug.

A spool position monitor point allows the function of the valve to be electrically monitored. Ramp functions, if required, can be generated externally.

Features and Benefits

- Factory-sealed adjustments increase valve-to-valve reproducibility.
- Valve with integrated amplifier selected, ordered, delivered and installed as one performance-tested package.
- Electronic feedback LVDT ensures accurate spool position control.
- Vibration and shock tested.
- Standard 24V DC supply with wide tolerance band.
- Wide range of spool and flow rate options.
- Standard $\pm 10V$ DC command signals.
- Installation wiring reduced and simplified.
- Standard 7-pin connector.
- Simple valve removal and replacement for service.
- Supported by auxiliary function modules.
- Full CE electromagnetic compatibility.
- IP67 environmental protection rating.
- Optional valve enable function.
- Optional pilot pressure reducer.

Typical Section View

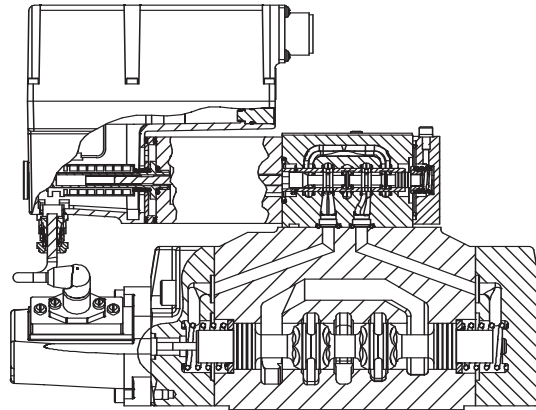

KBHDG5V-7, 10 design

Model Code

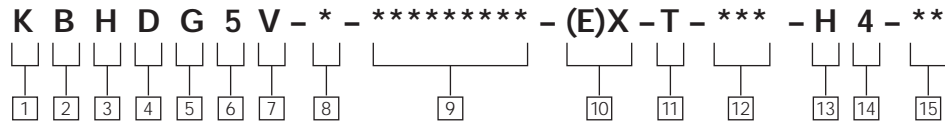

1 Valve type

K – Proportional valve

2 Integral amplifier

B – Integral amplifier “B” series

3 Feed back arrangement

H – From pilot and main stages

4 Control type

D - Directional valve

5 Mounting

G – Subplate mounted

6 Operation

5 – Solenoid controlled, pilot operated

7 Pressure rating

V – 310 bar (4500 psi) Size 05
 – 350 bar (5000 psi) Size 07
 – 350 bar (5000 psi) Size 08

8 Interface

ISO 4401
5 – Size 05
7 – Size 07
8 – Size 08

WARNING

 Valves with integral amplifiers are supplied with or without the metal 7-pin plug. The Vickers plug, part no. 934939, must be correctly fitted to ensure that the EMC rating and IP67 rating are achieved. The plug retaining nut must be tightened with a torque of 2-2,5 Nm (1.5-2.0 lbf ft) to effect a proper seal.

9 Spool type, flow rating and metering

See “Functional Symbol” on page 5. p = 5 bar (72 psi) per metering flow path, e.g. B to T.

Symmetric spools

For KBHGD5V-5 valves:

2C100N – 100 L/min (26 US gpm)

33C80N – 80 L/min (21 US gpm)

5C85N – 85 L/min (22 US gpm)

For KBHGD5V-7 valves:

2C200N – 200 L/min (52 US gpm)

33C160N – 160 L/min (42 US gpm)

5C200N – 200 L/min (52 US gpm)

For KBHGD5V-8 valves:

2C375N – 375 L/min (99 US gpm)

33C375N – 375 L/min (99 US gpm)

5C375N – 375 L/min (99 US gpm)

Asymmetric spools

First figure (**N) is flow rating P-A, or A-T (“A” port flow); last figure (N**) is flow rating P-B, or B-T (“B” port flow)

For KBHGD5V-5 valves:

2C70N45 – 70 L/min (18.5 US gpm), “A” port flow
 45 L/min (11.9 US gpm), “B” port flow

33C60N40 – 60 L/min (17.2 US gpm), “A” port flow
 40 L/min (10.6 US gpm), “B” port flow

For KBHGD5V-7 valves:

2C150N85 – 150 L/min (40 US gpm), “A” port flow;
 85 L/min (22.4 US gpm), “B” port flow

33C130N65 – 130 L/min (33.3 US gpm), “A” port flow;
 65 L/min (17.2 US gpm), “B” port flow

For KBHGD5V-8 valves:

2C375N250 – 375 L/min (99 US gpm), “A” port flow;
 250 L/min (66 US gpm), “B” port flow

12C375N250 – 375 L/min (99 US gpm), “A” port flow;
 250 L/min (66 US gpm), “B” port flow

33C375N250 – 375 L/min (99 US gpm), “A” port flow;
 250 L/min (66 US gpm), “B” port flow

133C375N250 – 375 L/min (99 US gpm), “A” port flow;
 250 L/min (66 US gpm), “B” port flow

733C375N250 – 375 L/min (99 US gpm), “A” port flow;
 250 L/min (66 US gpm), “B” port flow

72C375N250 – 375 L/min (99 US gpm), “A” port flow;
 250 L/min (66 US gpm), “B” port flow

For actual maximum flows refer to power capacity envelopes, page 8.

10 Pilot supply

Blank–Internal-no reducer

E – External (no reducer)

X – Internal (through integral reducer)

EX– External (through integral reducer)

See section on maximum pressures (page 7) for when pilot reducer must be used.

11 Pilot drain

T – Internal

Omit for external drain

12 Electrical connection

PC7 – 7 pin connector without plug

PE7 – 7 pin connector with plug

PH7 – As PE7 but with pin “C” used for enable signal

PR7 – As PC7 but with pin “C” used for enable signal

13 Coil rating

H – 24 VDC amplifier supply

14 Port T pressure limit rating

4 – 50 bar (700 psi) (for internal pilot drain option only, item 11 above)

15 Design number

10 – 10 series

Spool Data

Spool Symbols

Available Spools for KBHDG5V

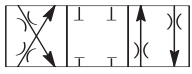

Spool type 2C

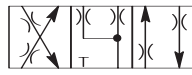

Spool type 33C

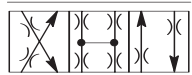

Spool type 5C (zero lapped)

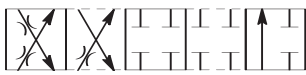

Spool type 12C



Spool type 133C

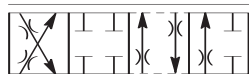

Spool type 72C

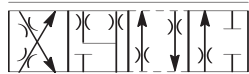

Spool type 733C

Spool Type and Flow Ratings

Symmetric Spools

Base line pressure drop $\Delta p = 5$ bar (72 psi) per metering flow path, e.g. B to T. For actual maximum flow refer to power capacity envelope curves.

Spool code	Spool symbol	Flow rating
For KBHDG5V-5 valves:		
2C100N	2C	100 L/min (26 USgpm)
33C80N	33C	80 L/min (21 USgpm)
5C85N	5C	85 L/min (22 USgpm)
For KBHDG5V-7 valves:		
2C200N	2C	200 L/min (52 USgpm)
33C160N	33C	160 L/min (42 USgpm)
5C200N	5C	200 L/min (52 USgpm)
For KBHDG5V-8 valves:		
2C375N	2C	375 L/min (99 USgpm)
33C375N	33C	375 L/min (99 USgpm)
5C375N	5C	375 L/min (99 USgpm)

Asymmetric Spools

Figure preceding metering type designator, "N" e.g. 2C**N) is flow rating P-A, or A-T ("A" port flow): Figure after "N" (N***) is flow rating P-B, or B-T ("B" port flow).

Note:

Valves with 5C spools are factory set so that with no command signal the pressure in port B is at least twice that in port A (blocked ports).

Spool code	Spool symbol	Flow rating
For KBHDG5V-5 valves:		
2C70N45	2C	70 L/min (18.5 USgpm) "A" port flow 45 L/min (11.9 USgpm) "B" port flow
33C60N40	33C	60 L/min (17.2 USgpm) "A" port flow 40 L/min (10.6 USgpm) "B" port flow
For KBHDG5V-7 valves:		
2C150N85	2C	150 L/min (40 USgpm) "A" port flow 85 L/min (22.4 USgpm) "B" port flow
33C130N65	33C	130 L/min (33.3 USgpm) "A" port flow 65 L/min (17.2 USgpm) "B" port flow
For KBHDG5V-8 valves:		
2C375N250	2C	375 L/min (99 USgpm) "A" port flow 250 L/min (66 USgpm) "B" port flow
33C375N250	33C	375 L/min (99 USgpm) "A" port flow 250 L/min (66 USgpm) "B" port flow
12C375N250	12C	375 L/min (99 USgpm) "A" port flow 250 L/min (66 USgpm) "B" port flow
133C375N250	133C	375 L/min (99 USgpm) "A" port flow 250 L/min (66 USgpm) "B" port flow
72C375N250	72C	375 L/min (99 USgpm) "A" port flow 250 L/min (66 USgpm) "B" port flow
733C375N250	733C	375 L/min (99 USgpm) "A" port flow 250 L/min (66 USgpm) "B" port flow

Functional Symbol

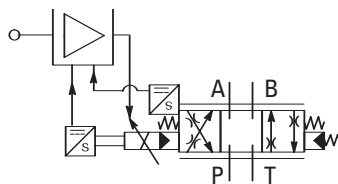

Simplified Symbol

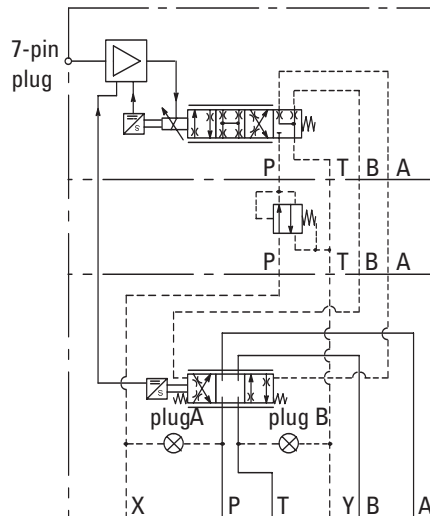

Detailed Symbol

Application Notes

A. Main-Spool Options

Spools shown are meter-in/meter-out types. Center-condition options are types 2, 33, 5, 12, 133, 72 and 733.

B. Internally Piloted Models

Differ from detailed symbols above by omission of plug A and the blocking of port X by the mating surface.

C. Internally Pilot Drain Models

Differ from detailed symbols above by omission of plug B and blocking of port Y by the mating surface.

Operating Data

Data is typical with fluid at 36 cSt (168 SUS) and 50 C (122 F).

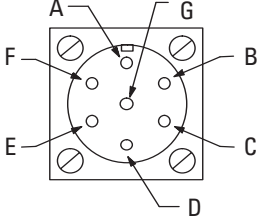
Power supply	24V DC (21V to 36V including 10% peak-to-peak max. ripple) max current 3A																		
Command signal	0 to +10V DC, or 0 to -10V DC, or -10 V to +10 V DC																		
Input impedance	47 k Ω																		
Common mode voltage to pin B	18V (max)																		
Valve enable signal for model codes PH7 & PR7																			
Enable	>8.5V (36V max)																		
Disable	<6.5V																		
Input impedance	10 k Ω																		
7-pin plug connector	<div style="display: flex; align-items: center;">  <div style="margin-left: 20px;"> <table border="1"> <thead> <tr> <th>Pin</th> <th>Description</th> </tr> </thead> <tbody> <tr> <td>A</td> <td>Power supply positive</td> </tr> <tr> <td>B</td> <td>Power 0V</td> </tr> <tr> <td>C</td> <td>Monitor 0V (PE7 & PC7)</td> </tr> <tr> <td>D</td> <td>Valve enable (PH7 & PR7)</td> </tr> <tr> <td>E</td> <td>Command signal (+)-non-inverting input</td> </tr> <tr> <td>F</td> <td>Command signal (-)-inverting input</td> </tr> <tr> <td>G</td> <td>Monitor output</td> </tr> <tr> <td></td> <td>Protective ground</td> </tr> </tbody> </table> </div> </div>	Pin	Description	A	Power supply positive	B	Power 0V	C	Monitor 0V (PE7 & PC7)	D	Valve enable (PH7 & PR7)	E	Command signal (+)-non-inverting input	F	Command signal (-)-inverting input	G	Monitor output		Protective ground
Pin	Description																		
A	Power supply positive																		
B	Power 0V																		
C	Monitor 0V (PE7 & PC7)																		
D	Valve enable (PH7 & PR7)																		
E	Command signal (+)-non-inverting input																		
F	Command signal (-)-inverting input																		
G	Monitor output																		
	Protective ground																		
View of pins of fixed half																			
Electromagnetic compatibility (EMC):																			
Emission (10 V/m)	EN 50081-2																		
Immunity (10 V/m)	EN 50082-2																		
Threshold command voltage (minimum voltage for minimum flow)	0V – 5C Spools 0.25V– 2C & 33C Spools																		
Monitor signal (pin F)	\pm 10V DC for full spool stroke																		
Output impedance	10k Ω																		
Power stage PWM frequency	10 kHz nominal																		
Step input response, with flow through P–A–B–T, $\Delta p=5$ bar (72 psi) per metering path, e.g. P–A																			
Required flow step:	Time to reach 90% of required step:																		
KBHDG5V–5	0 to 100% 100% to 0 +90 to -90%	24 ms 23 ms 35 ms																	
KBHDG5V–7	0 to 100% 100% to 0 +90 to -90%	24 ms 23 ms 36 ms																	
KBHDG5V–8	0 to 90% 90% to 0 +90 to -90%	31 ms 31 ms 49 ms																	
Reproducibility, valve-to-valve (at factory settings): Flow at 100% command signal	\leq 5%																		
Hysteresis with flow through P-A-B-T $\Delta p=5$ bar (72 psi) per metering path (P–A or B–T)	<1%																		
Protection:																			
Electrical	Reverse polarity protected																		
Environmental	IEC 144, Class IP67																		
Ambient air temperature range for full performance	0° C to 70° C (32° F to 158° F)																		
Oil temperature range for full performance	0° C to 70° C (32° F to 158° F)																		
Minimum temperature at which valves will work at reduced performance	-20° C (-4° F)																		
Storage temperature range	-25° C to +85° C (-13° F to +185° F)																		
Relative duty factor	Continuous rating (ED = 100%)																		
Mass:																			
Valves with pressure reducer	KBHDG5V-5 10,15 kg (22.4 lb) approx. KBHDG5V-7 11,4 kg (25.1 lb) approx. KBHDG5V-8 17,05 kg (37.54 lb) approx.																		
Valves without pressure reducer	KBHDG5V-5 8,85 kg (19.5 lb) approx. KBHDG5V-7 10,1 kg (22.2 lb) approx. KBHDG5V-8 15,85 kg (34.84 lb) approx.																		
Supporting products:																			
Auxiliary electronic modules (DIN -rail mounting):																			
EHA-CON-201-A2* signal converter	See catalog GB 2410B																		
EHD-DSG-201-A-1* command signal generator	See catalog GB 2470																		
EHA-RMP-201-A-2* Ramp generator	See catalog GB 2410A																		
EHA-PSU-201-A-10 Power supply	See catalog GB 2410A																		
EHA-PID-201-A-20 PID controller	See catalog GB 2427																		

Pressure and Minimum Flow Rates

MAXIMUM PRESSURES, BAR (PSI) VALVES WITH PRESSURE REDUCER

Model	Pilot pressure source †	Pilot drain connection	P Port	A&B Ports	T Port	X Port ◆	Y Port
KBHDG5V-5	External	External	315 (4500)	315 (4500)	210 (3000)	210 (3000)	50 (700)
		Internal*	315 (4500)	315 (4500)	50 (700)	315 (4500)	50 (700)
	Internal	External	315 (4500)	315 (4500)	100 (1500)	315 (4500)	50 (700)
		Internal*	315 (4500)	315 (4500)	50 (700)	315 (4500)	50 (700)
KBHDG5V-7	External	External	350 (5000)	350 (5000)	350 (5000)	350 (5000)	50 (700)
		Internal*	350 (5000)	350 (5000)	50 (700)	350 (5000)	50 (700)
	Internal	External	350 (5000)	350 (5000)	350 (5000)	350 (5000)	50 (700)
		Internal*	350 (5000)	350 (5000)	50 (700)	350 (5000)	50 (700)
KBHDG5V-8	External	External	350 (5000)	350 (5000)	350 (5000)	350 (5000)	50 (700)
		Internal*	350 (5000)	350 (5000)	50 (700)	350 (5000)	50 (700)
	Internal	External	350 (5000)	350 (5000)	350 (5000)	350 (5000)	50 (700)
		Internal*	350 (5000)	350 (5000)	50 (700)	350 (5000)	50 (700)

† Minimum recommended pilot operating pressure = 50 bar (700 psi)

* Internal drain is a non-preferred option

◆ For pilot pressures ≤ 210 bar (3000 psi) a pilot pressure reducer is optional
For pilot pressures > 210 bar (3000 psi) a pilot pressure reducer must be used

Unused pilot port: Maximum pressure as shown

MAXIMUM PRESSURES, BAR (PSI) VALVES WITHOUT PRESSURE REDUCER

Model	Pilot pressure source †	Pilot drain connection	P Port	A&B Ports	T Port	X Port ◆	Y Port
KBHDG5V-5	External	External	315 (4500)	315 (4500)	210 (3000)	210 (3000)	50 (700)
		Internal*	210 (3000)	315 (4500)	50 (700)	210 (3000)	50 (700)
	Internal	External	210 (3000)	315 (4500)	210 (3000)	210 (3000)	50 (700)
		Internal*	315 (4500)	315 (4500)	50 (700)	210 (3000)	50 (700)
KBHDG5V-7/8	External	External	350 (5000)	350 (5000)	350 (5000)	210 (3000)	50 (700)
		Internal*	350 (5000)	350 (5000)	50 (700)	210 (3000)	50 (700)
	Internal	External	210 (3000)	350 (5000)	350 (5000)	210 (3000)	50 (700)
		Internal*	210 (3000)	350 (5000)	50 (700)	210 (3000)	50 (700)

† Minimum recommended pilot operating pressure = 50 bar (700 psi)

* Internal drain is a non-preferred option

◆ For pilot pressures ≤ 210 bar (3000 psi) a pilot pressure reducer is optional
For pilot pressures > 210 bar (3000 psi) a pilot pressure reducer must be used

Unused pilot port: Maximum pressure as shown

MINIMUM RECOMMENDED FLOW RATES

Valve Size/Spool Code	Min. Flow Rate L/min	In ³ /min
KBHDG5V-5-2C100N	0,5	30
KBHDG5V-5-33C80N	0,5	30
KBHDG5V-7-2C200N	1,0	60
KBHDG5V-7-33C160N	1,0	60
KBHDG5V-8-2C375	1,5	91
KBHDG5V-8-33C375	1,5	91

For spool types 2C and 33C

Δp = 10 bar (142 psi) for looped flow P-A-B-T (or P-B-A-T)

Performance Curves

KBHDG5V-5/7/8

FLOW GAIN

At $\Delta p = 5 \text{ bar (72 psi)}$ per metering path (e.g. P-A), with flow through P-A-B-T or P-B-A-T. Percentage command signals applicable for positive and negative values of command signal.

At other Δp values, flow rates approximate to: $Q_x = Q_D \sqrt{\frac{\Delta p_x}{\Delta p_D}}$
 where $Q_D =$ Datum flow rate
 $\Delta p_D =$ Pressure drop at datum flow rate
 $\Delta p_x =$ Required Δp

Limited by valve power capacity. Refer to curves on page 8.

POWER CAPACITY ENVELOPE
Flow through P-A-B-T or P-B-A-T
US gpm

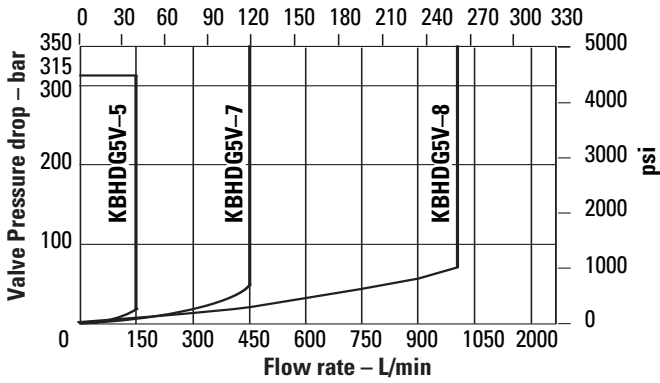

PRESSURE GAIN
("5C" spools only)

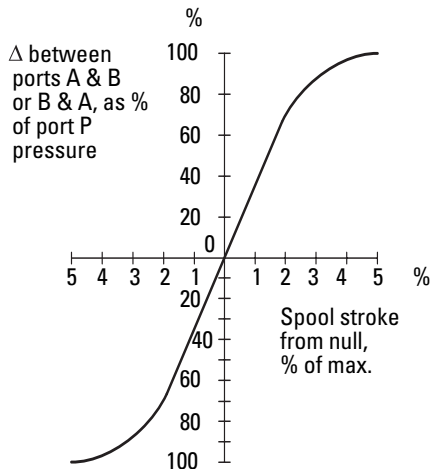

FREQUENCY RESPONSE, TYPICAL
For an amplitude of $\pm 25\%$ of max. stroke (center-to-offset) about the 50% position

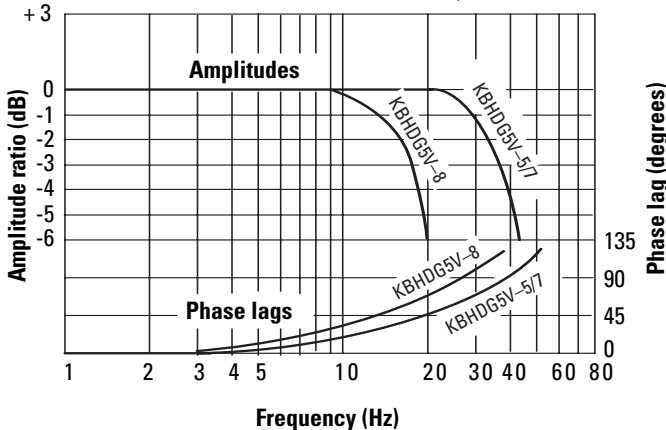

"2C" Spools

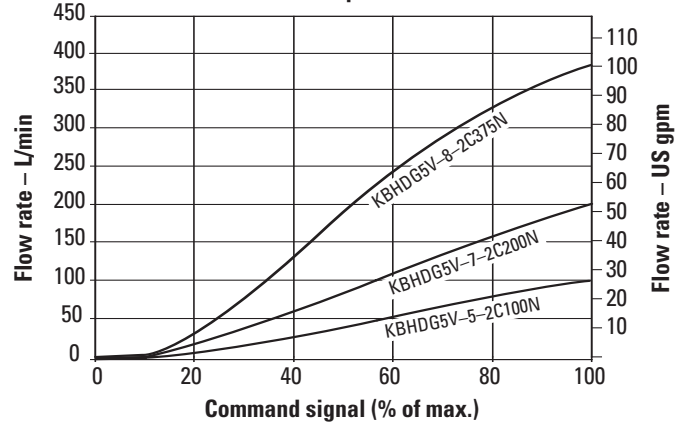

"5C" Spools

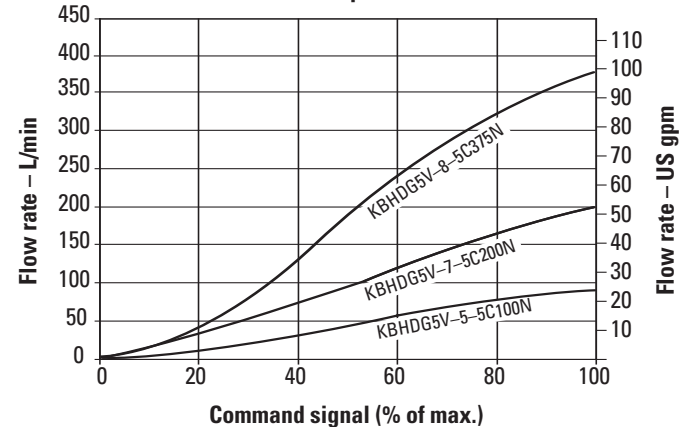

"33C" Spools

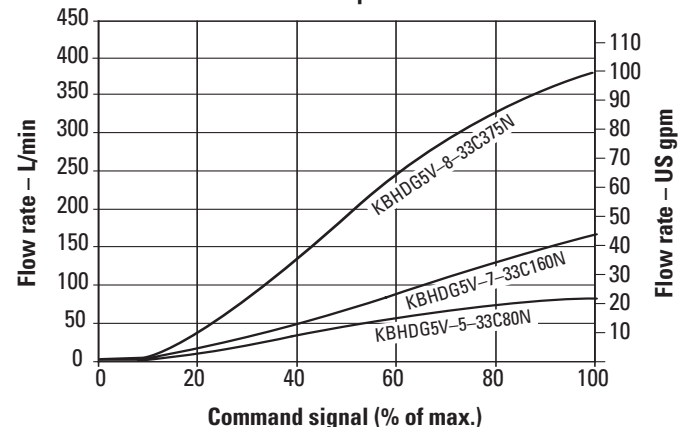

Performance Curves

Flow Gain

Chart Legend:

A = P to A	C = A to T
B = P to B	D = B to T

KBHDG5V-5

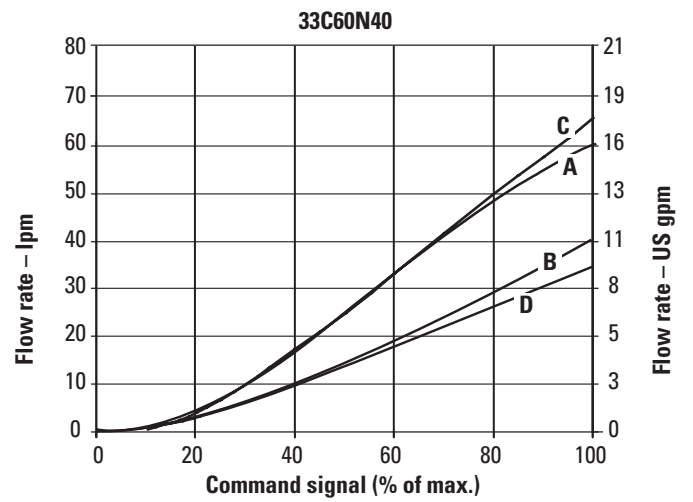
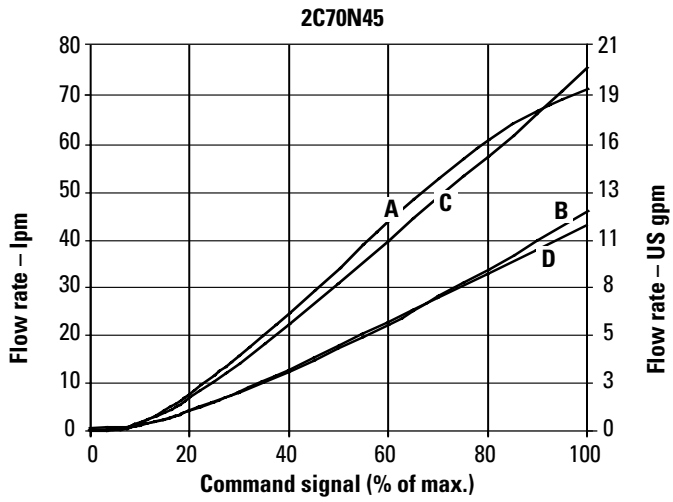

KBHDG5V-7

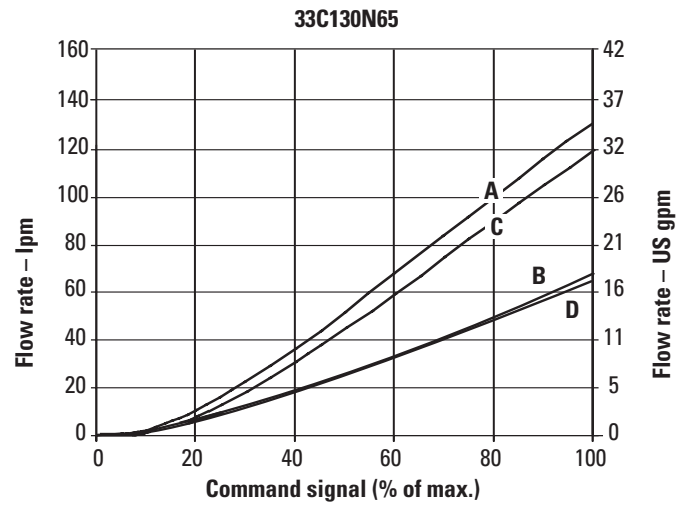
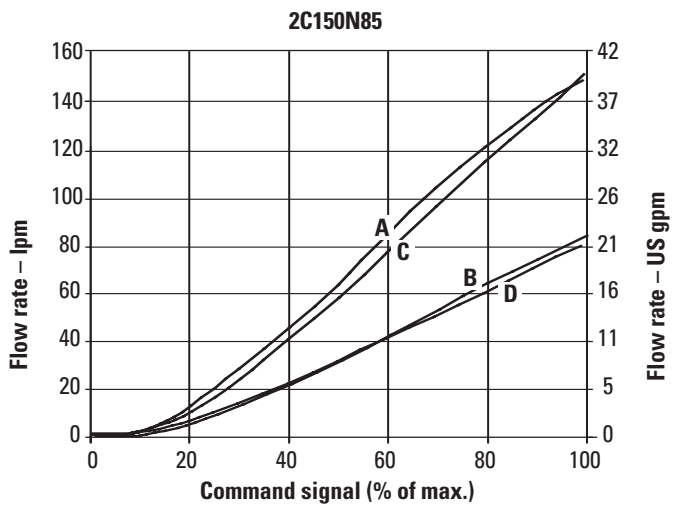

Performance Curves

KBHDG5V-8

Chart Legend:

- | | |
|-------------------|-------------------|
| A = P to A | C = A to T |
| B = P to B | D = B to T |

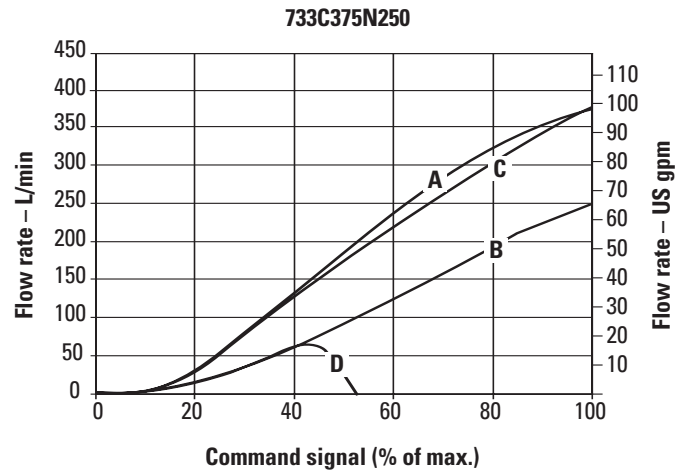
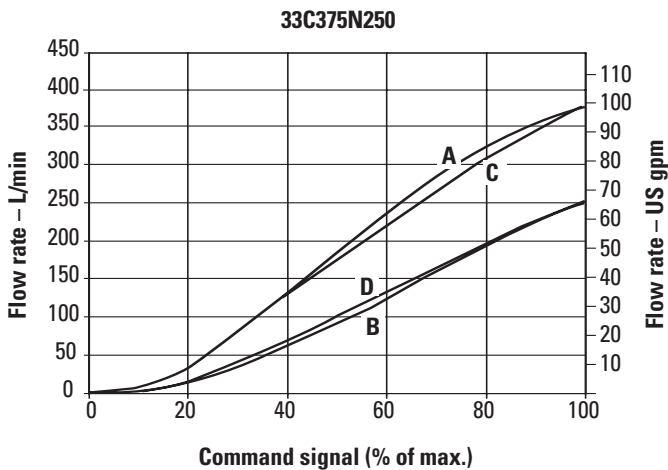
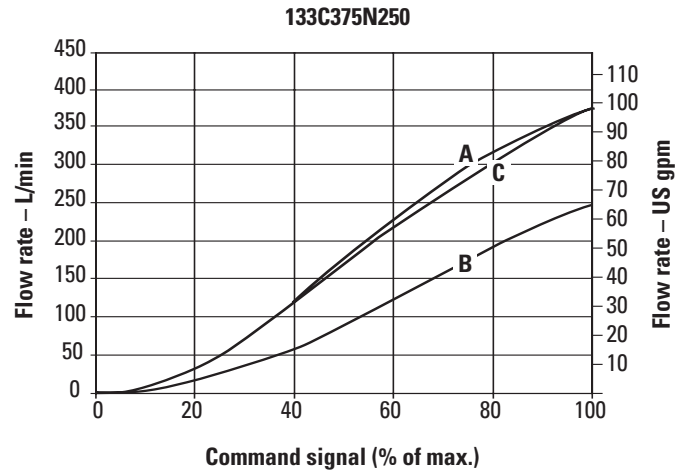
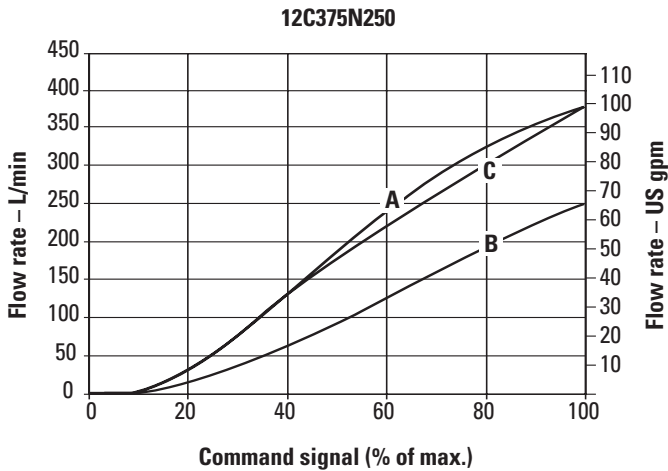
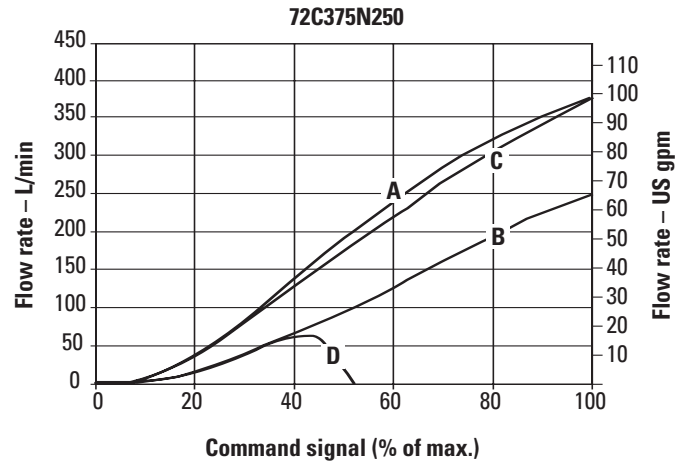
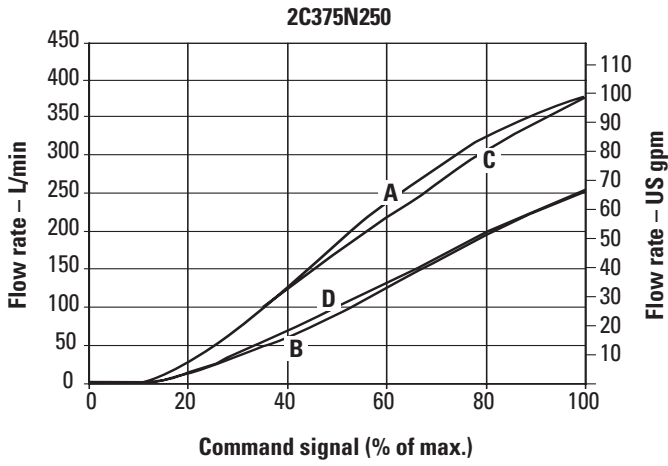

Installation Dimensions

KBHDG5V-5/7

KBHDG5V-5

mm (Inch)

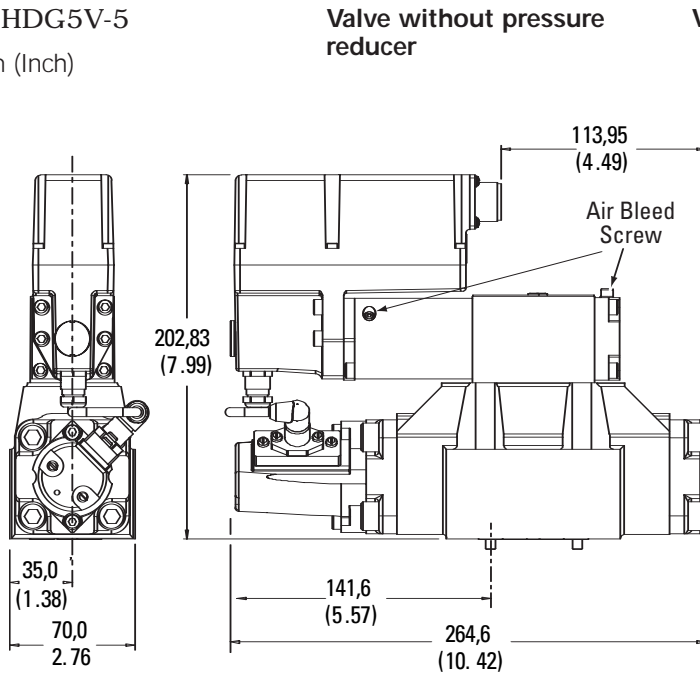

Valve with pressure reducer

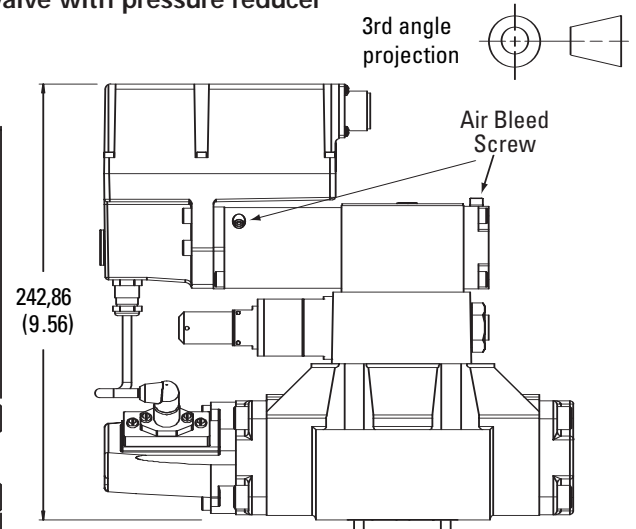

Mounting surface, seals supplied. For mating surface dimensions, see page 12 (size 05 with additional X and Y ports). For mounting subplate options and bolt options, see catalog GB-2425.

KBHDG5V-7

mm (Inch)

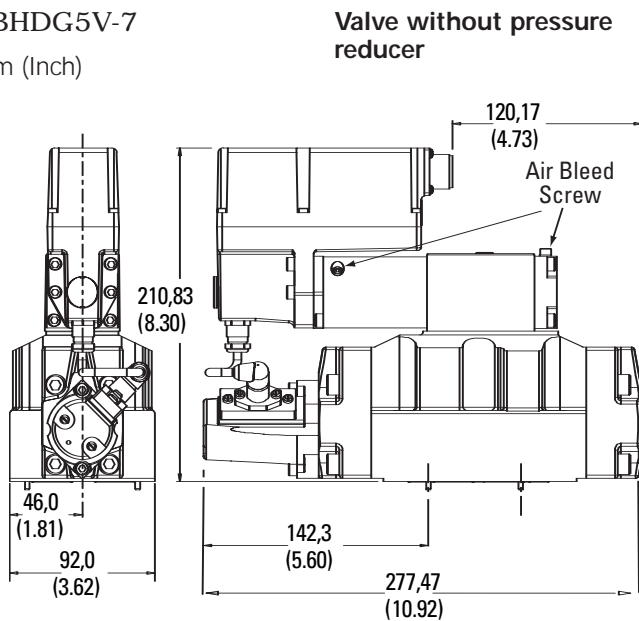

Valve with pressure reducer

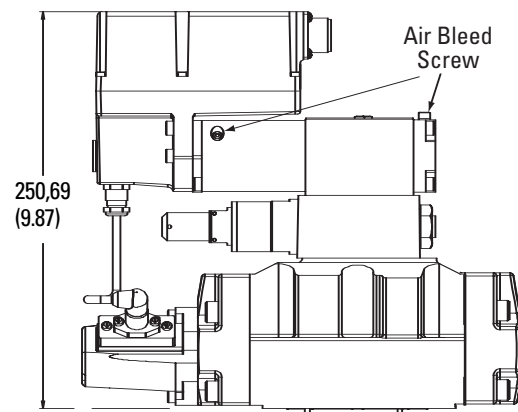

Mounting surface, seals supplied. For mating surface dimensions, see page 13. For mounting subplate options and bolt options, see catalog GB-2425.

Installation Dimensions

KBHDG5V-8

KBHDG5V-8
mm (Inch)

Valve without pressure reducer

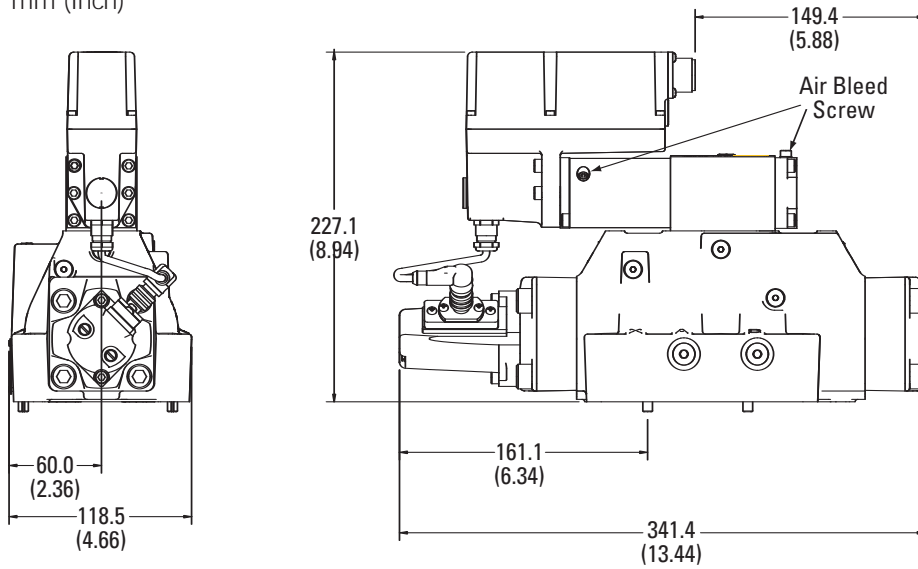

Mounting surface, seals supplied. For mating surface dimensions, see page 13. For mounting subplate options and bolt options, see catalog GB-2425.

Valve with pressure reducer

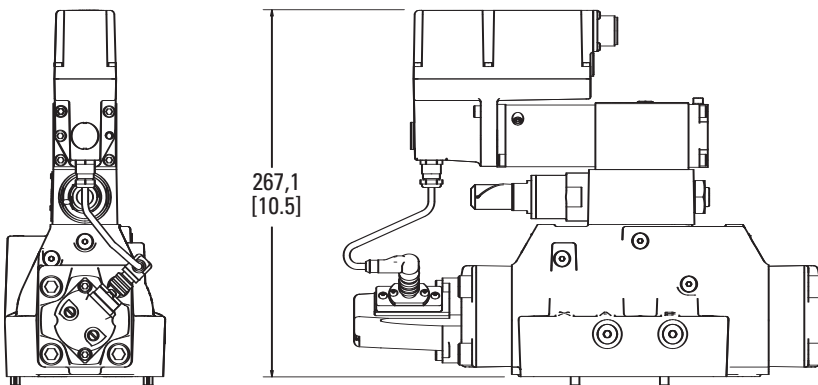

Mounting Surfaces

General Description

When a subplate is not used, a machined pad must be provided for valve mounting. Pad must be flat within 0,0127 mm (.0005 inch) and smooth within 1.6 mm (63 microinch). Mounting bolts, when provided by customer, should be ISO 898 class 12.9 or better. Bolt Kits See page 16.

Dimensional Tolerances

Dimensional tolerance on interface drawings is 0,2 mm (0.008") except where otherwise stated. ISO 4401 specifies inch conversion to 0.01".

Conversion from Metric

ISO 4401 gives dimensions in mm. Inch conversions are accurate to 0.01" unless otherwise stated.

Mounting Bolt Tappings

ISO 4401 gives metric thread tappings. Alternate UNC tappings are Vickers recommendations that allow these

plates and associated valves to be used up to their maximum pressures, when using Vickers recommended bolt kits, or bolts of an equivalent strength. It is recommended that Customer's own manifold blocks for UNC bolts should be tapped to the minimum depths given in the footnotes.

Mounting Surface Interface ISO 4401-05

Vickers Standard Size 05 Interface

This interface conforms to ISO 4401-054-0-94, NSI/B93.7M (and NFPA) size 05, CETOP R35H4 2-05, DIN 24340 Form A10.

◆ 1/4" -20 UNC-2B optional.

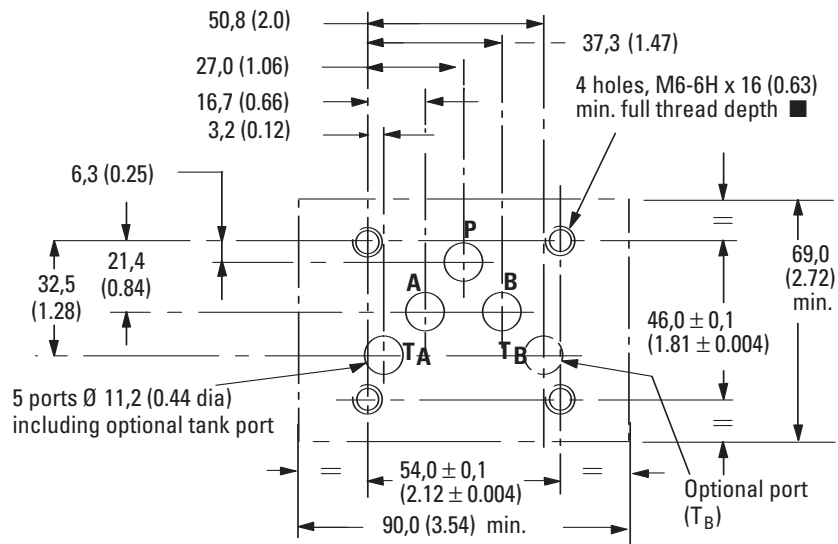

Interface with additional pilot ports X and Y

This interface conforms to Vickers standard, plus holes X and Y ISO 4401-054-0-94.

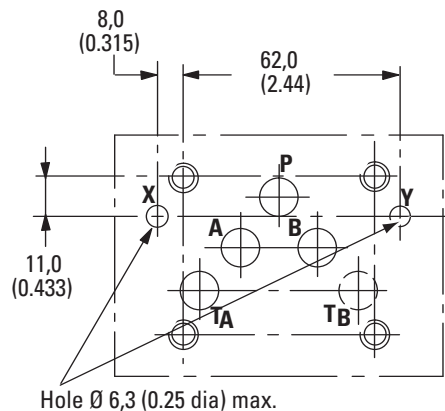

Mounting Surfaces

Vickers Standard Size 07 Interface

This interface conforms to:
 ISO 4401-07-06-0-94
 ANSI/B93.7M (and NFPA)
 size 07 CETOP R35H4.3-07
 DIN 24340 Form A16

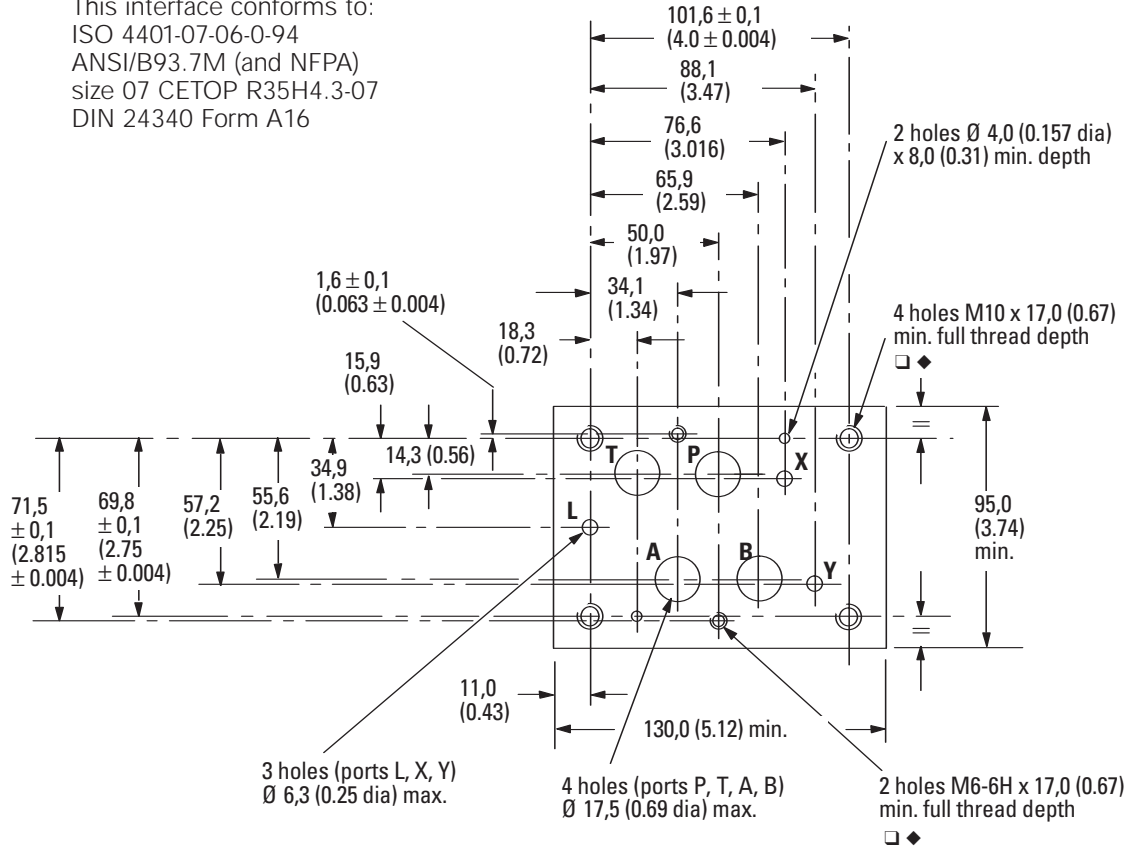

□ 3/8 -16 UNC optional.

◆ 1/4 -20 UNC optional.

Vickers Standard Size 08 Interface

This interface conforms to:
 ISO 4401-08-07-0-94
 ANSI/B93.7M (and NFPA)
 size 08 CETOP R35H4.3-08
 DIN 24340 Form A25

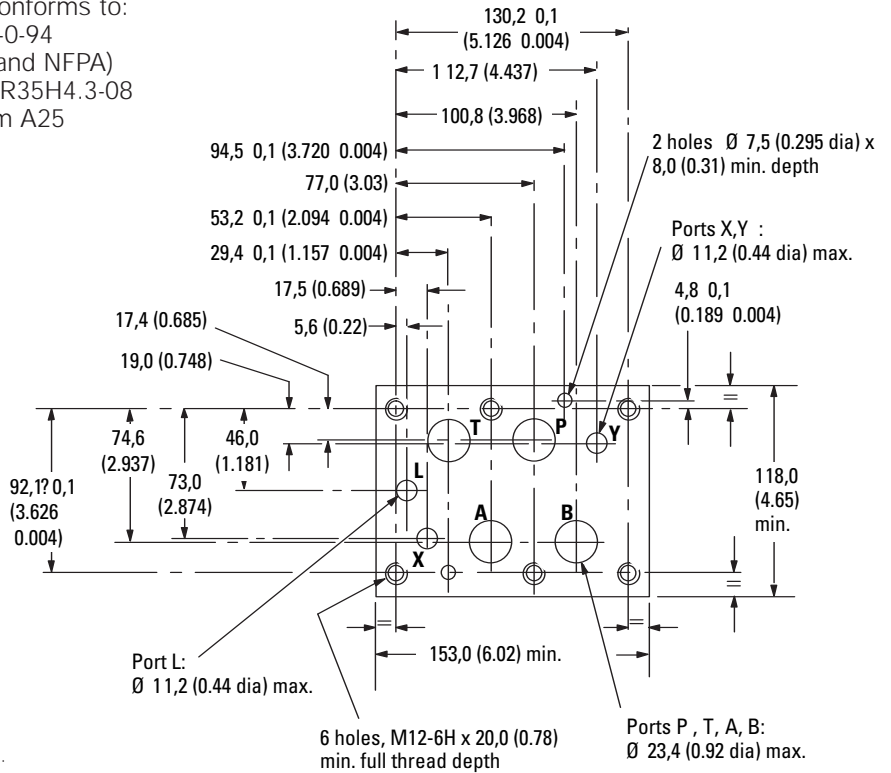

■ 1/2 -13 UNC optional.

◆ Vickers uses port L for pressure-centered and other options not in high demand.

Electrical Information

Electrical Block Diagram

Wiring

Connections must be made via the 7-pin plug mounted on the amplifier. See page NO TAG of this leaflet and Installation and Start-up Guidelines, ML-B-9090A for cable recommendations.

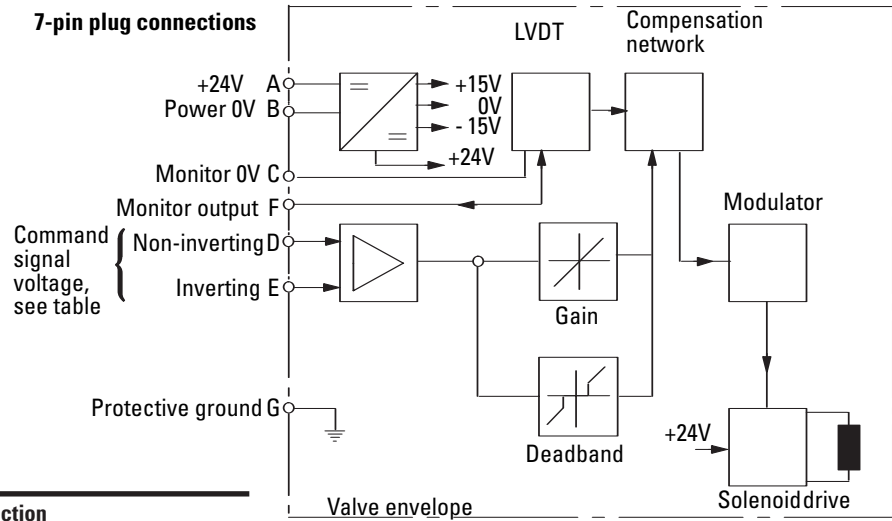

COMMAND SIGNALS AND OUTPUTS

7-pin plug	Flow direction	
Pin D	Pin E	
Positive	0V	P to A
0V	Negative	
$U_D - U_E = \text{Positive}$		
Negative	0V	P to B
0V	Positive	
$U_D - U_E = \text{Negative}$		

▲Note: In valves with PH7 or PR7 type electrical connection, pin C is used for a valve enable signal.



WARNING

All power must be switched off before connecting or disconnecting any plugs.

Electrical Information

Typical Connection Arrangements

Wiring Connections

■ Spool position monitor voltage (pin F) will be referenced to the KB valve local ground. A "local ground" (pin C) is provided on PC7/PE7 versions for optional use by differential input customer supplied electronics.



WARNING

Do not ground pin C. If the local ground (pin C) is not used for differential monitor electronics, do not use. Read monitor pin F with respect to ground.

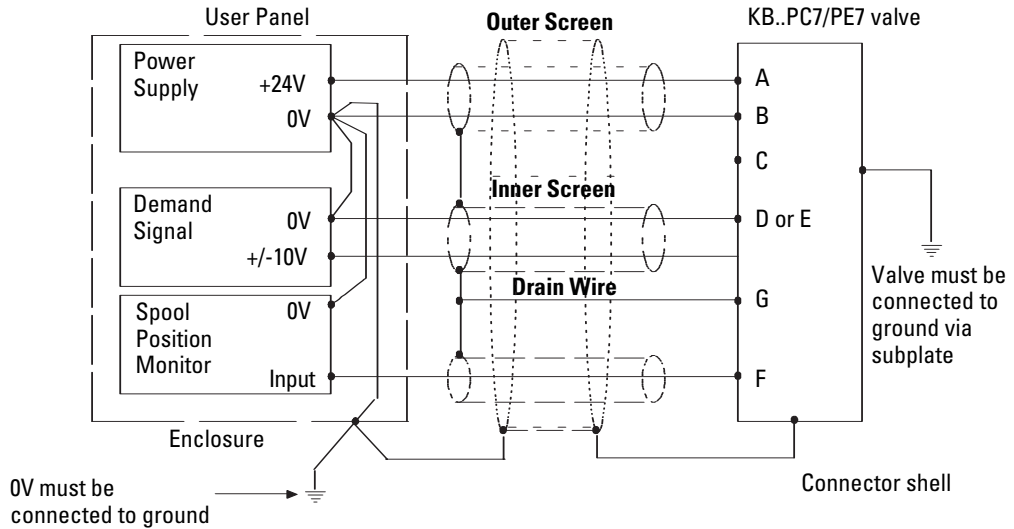

Wiring Connections for Valves with Enable Feature

▲Note:

In applications where the valve must conform to European RFI/EMC regulations, the outer screen (shield) must be connected to the outer shell of the 7 pin connector, and the valve body must be fastened to the earth ground. Proper earth grounding practices must be observed in this case, as any differences in command source and valve ground potentials will result in a screen (shield) ground loop.

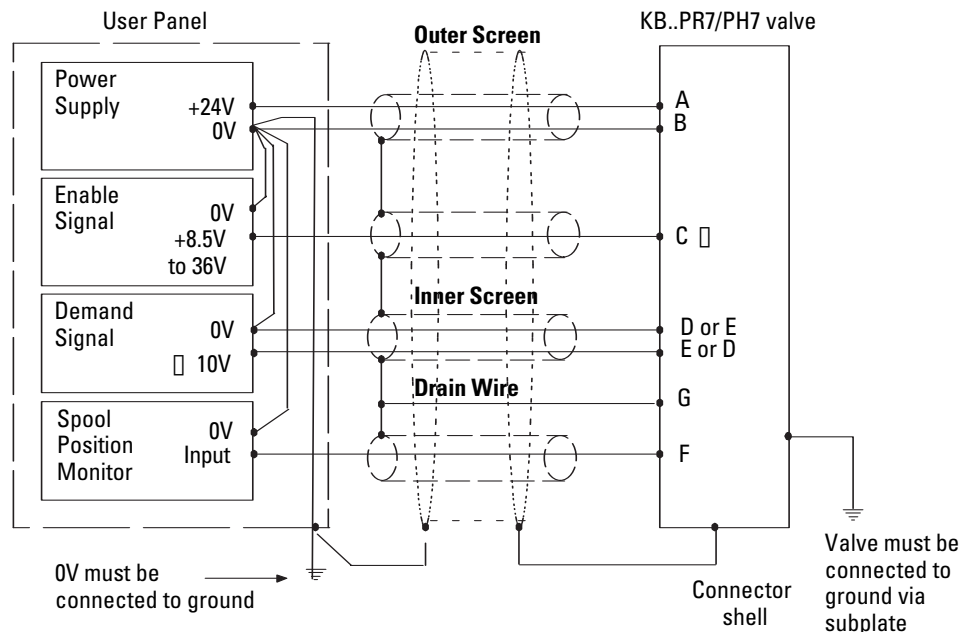

WARNING

Electromagnetic Compatibility (EMC)

It is necessary to ensure that the valve is wired up as above. For effective protection the user electrical cabinet, the valve subplate or manifold and the cable screens should be connected to efficient ground points.

The metal 7 pin connector part no. 934939 should be used for the integral amplifier. In all cases both valve and cable should be kept as far away as possible from any sources of electromagnetic radiation such as cables carrying heavy current, relays and certain kinds of portable radio transmitters, etc.

Difficult environments could mean that extra screening may be necessary to avoid the interference. It is important to connect the 0V lines as shown above. The multicore cable should have at least two screens to separate the demand signal and monitor output from the power lines. The enable line

to pin C should be outside the screen which contains the demand signal cables.

Application Data

Fluid Cleanliness

Proper fluid condition is essential for long and satisfactory life of hydraulic components and systems. Hydraulic fluid must have the correct balance of cleanliness, materials and additives for protection against wear of components, elevated viscosity and inclusion of air.

Recommendations on contamination control methods and the selection of products to control fluid condition are included in Vickers publication 9132 or 561, "Vickers Guide to Systemic Contamination Control". The book also includes information on the Vickers concept of "ProActive Maintenance". The following recommendations are based on ISO cleanliness levels at 2 µm, 5 µm and 15 µm

For products in this catalog the recommended levels are:

0 to 70 bar (1000 psi) – 18/16/13

70 + bar (1000 + psi) – 17/15/12

Vickers products, as any components, will operate with apparent satisfaction in fluids with higher cleanliness codes than those described. Other manufacturers will often recommend levels above those specified.

Experience has shown, however, that life of any hydraulic components is shortened in fluids with higher cleanliness codes than those listed above. These codes have been proven to provide a long trouble-free service life for the products shown, regardless of the manufacturer.

Hydraulic Fluids

Materials and seals used in these valves are compatible with antiwear hydraulic oils, and non-alkyl-based phosphate esters. The extreme operating viscosity range is 500 to 13 cSt (2270 to 70 SUS) but the recommended running range is 54 to 13 cSt (245 to 70 SUS). For further technical information about fluids see "Technical Information" leaflet B-920 or I-286S.

Installation

The proportional valves in this catalog can be mounted in any attitude, but it may be necessary in certain demanding applications, to ensure that the solenoids are kept full of hydraulic fluid. Good installation practice dictates that the tank port and any drain port are piped so as to keep the valves full of fluid once the system start-up has been completed.

Mounting Bolt Kits

For KBHDG5V-5

BKDG01633M (metric)

BKDG01633 (inch)

For KBHDG5V-7

BKDG7 858918 (metric)

BK590724 (inch)

For KBHDG5V-8

BKDG8-655M (metric)

BKDG06-635 (inch)

If not using Vickers recommended bolt kits, bolts used should be to ISO 898, 12.9 or better.

Seal Kits

KBHDG5V-502-350518

KBHDG5V-702-350519

KBHDG5V-802-350686

Plugs

KBHDG5V

7-pin plug (metal)934939

7-pin plug (plastic)694534

(metal plug must be used for full EMC protection)

Note:

An alternative metal connector which gives EMC protection but not IP67 rating is available from ITT-Cannon, part number CA06-COM-E-14S-A7-S.

Extension Cable

Extension Cable: Adapter for extending 7 core cable when changing from KA to KB valve and existing wiring is not long enough. Consists of a 7 pin plug, a 7 pin socket and a length of cable, fully assembled for ease of use
Extension Cable.....944450

Service Information

The products from this range are preset at the factory for optimum performance; disassembling critical items would destroy these settings. It is therefore recommended that should any mechanical or electronic repair be necessary they should be returned to the nearest Vickers repair center. The products will be refurbished as necessary and retested to specification before return.

Field repair is restricted to the replacement of the seals.

Note:

The feedback/solenoid assembly installed in this valve should not be disassembled.

Eaton
14615 Lone Oak Road
Eden Prairie, MN 55344
USA
Tel: 952 937-9800
Fax: 952 974-7722
www.hydraulics.eaton.com

Eaton
20 Rosamond Road
Footscray
Victoria 3011
Australia
Tel: (61) 3 9319 8222
Fax: (61) 3 9318 5714

Eaton
Dr.-Reckeweg-Str. 1
D-76532 Baden-Baden
Germany
Tel: (49) 7221 682-0
Fax: (49) 7221 682-788

VICKERS[®]

EATON

Vickers

© 2004 Eaton Corporation
All Rights Reserved
Printed in USA
Document No. V-VLDI-MC001-E
September 2004